

Description

RKBI is an insulated centrifugal duct fan with connections for rectangular ducts. The fan have a rigid housing of galvanised steel and are compact with high capacity. With the 50 mm high quality insulation it operates quiet and the surface of the insulation is easy to clean. RKBI is available in 16 capacities. The backward curved impeller gives a better efficiency over a very big working area than the forward curved impeller. The fan is designed to cope with high pressures i.e. long ducts with a minimum of noise. The motor is speed-controllable from 0-100% and maintenance-free, why the only service required is cleaning the impeller. Motor with impeller can be swung out for inspection and cleaning (swing-out). The RKBI fan is supplied fully-wired and ready to fit in a sealed installation unit. It is moisture-proof and approved for use in warm or cold environments. All fans are fitted with a built-in thermal protector.



Technical data

Parameter	Value	Unit
Voltage	400	V
Phase	3	~
Frequency	50	Hz
Power	0.34	kW
Current	1.04	A
R.p.m.	24	r/s
Max. temperature of transported air	75	°C
Max. temperature of transported air when speed-controlled	75	°C
Sound pressure level at 3 m	44	dB(A)
Length	747	mm
Width	707	mm
Height	489	mm
Weight	52	kg
Enclosure class, motor	44	IP
Insulation class, motor	F	
Duct connection	600x350 mm	

Diagrams

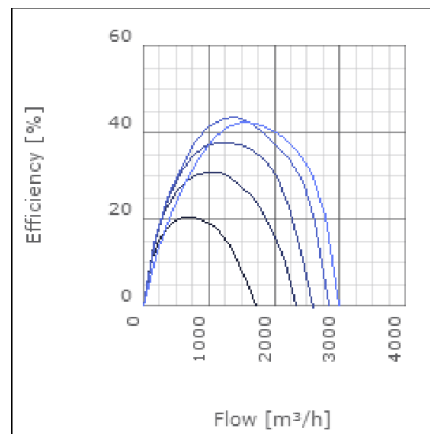
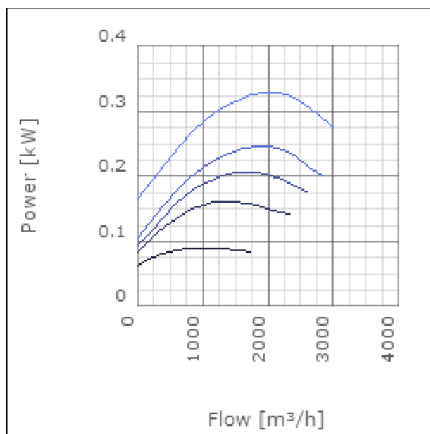
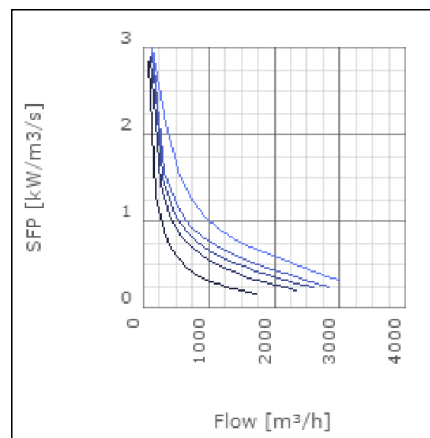
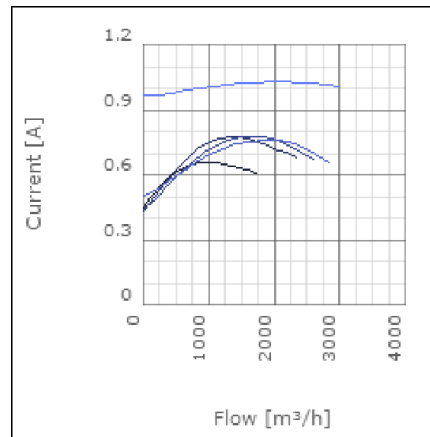
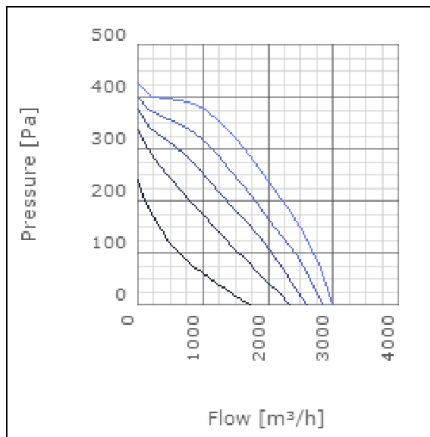

Sound

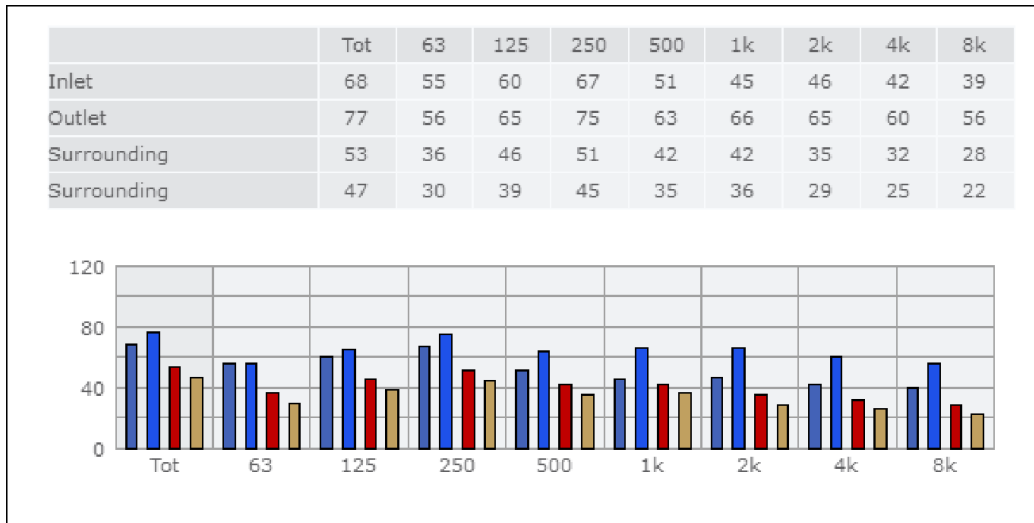

Parameter

Distance: 3.000
 Propagation type: Hemi-spherical
 Equivalent absorption area: 20.00

Checked point

Flow 1679.856m³/h
 Static pressure 294Pa

Working point

Flow 1681.007m³/h
 Static Pressure 294Pa
 Power 0.32kW
 Speed 0r/s
 Current 1.03A
 Voltage 400V
 Efficiency 42.361%
 SFP 0kW/m³/s

Dimensions

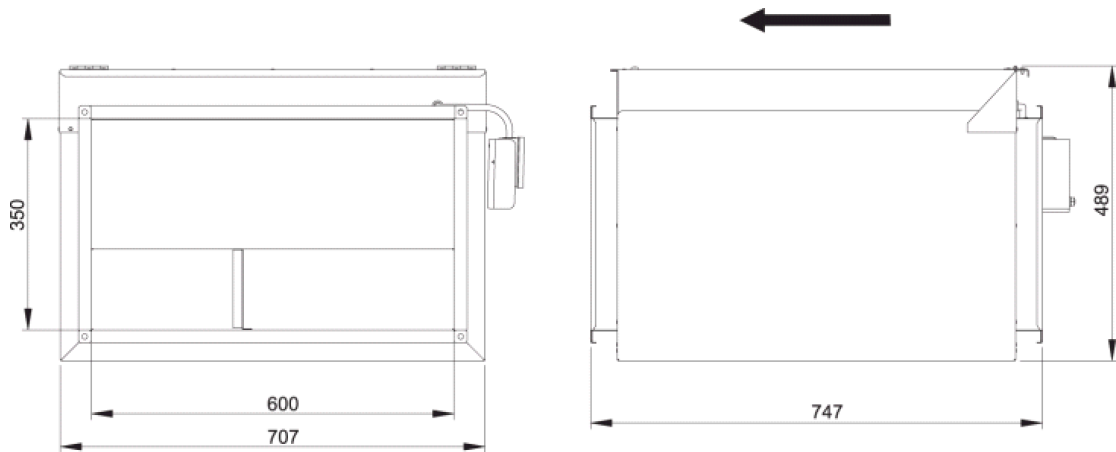

Wiring diagram

4040004

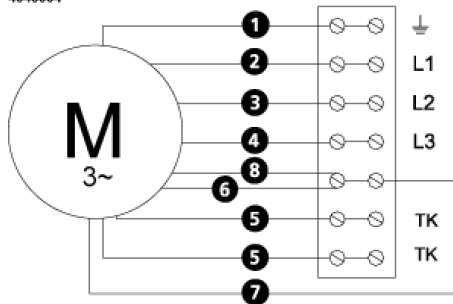

- (M) = Fan Motor
- (M1) = Fan Motor
- (M2) = Fan Motor
- (M3) = Rotor Motor
- 1 = Yellow/Green
- 2 = Black
- 3 = Blue
- 4 = Brown
- 5 = White (TW)
- 6 = Orange
- 7 = Grey
- 8 = Red
- 9 = Green
- 10 = Violet

Accessories

VRDT 2
VRTT 2

Electrical accessories

FLR 600x350
DS 600x350
LDR 600x350